

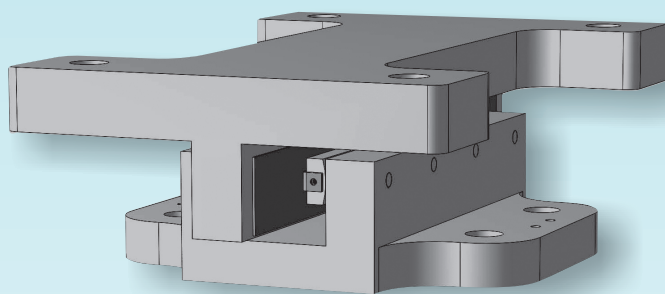

FE Restraint & Guide Bearings



Description

The FE Series are designed to resist only horizontal loads. Restraint and guide bearings are available as standard for loads up to 2000 kN. The bearings fully meet the requirements of EN1337-8.

Bearing Types

The FE range of bearings are available in three forms: -

- 10FE** Restraint
- 21FE** Guided
- 31FE** Enhanced guided

In addition to these fundamental features all the above bearings have a capacity for vertical translation, which in accordance with EN1337-8, equates to 15mm positive translation and 10mm negative translation. This feature provides the added benefit that these bearings can be considered as part of a client's temporary works restraint criteria during a bearing replacement, as the guide/restraint should never disengage.

Typical 21/31FE details

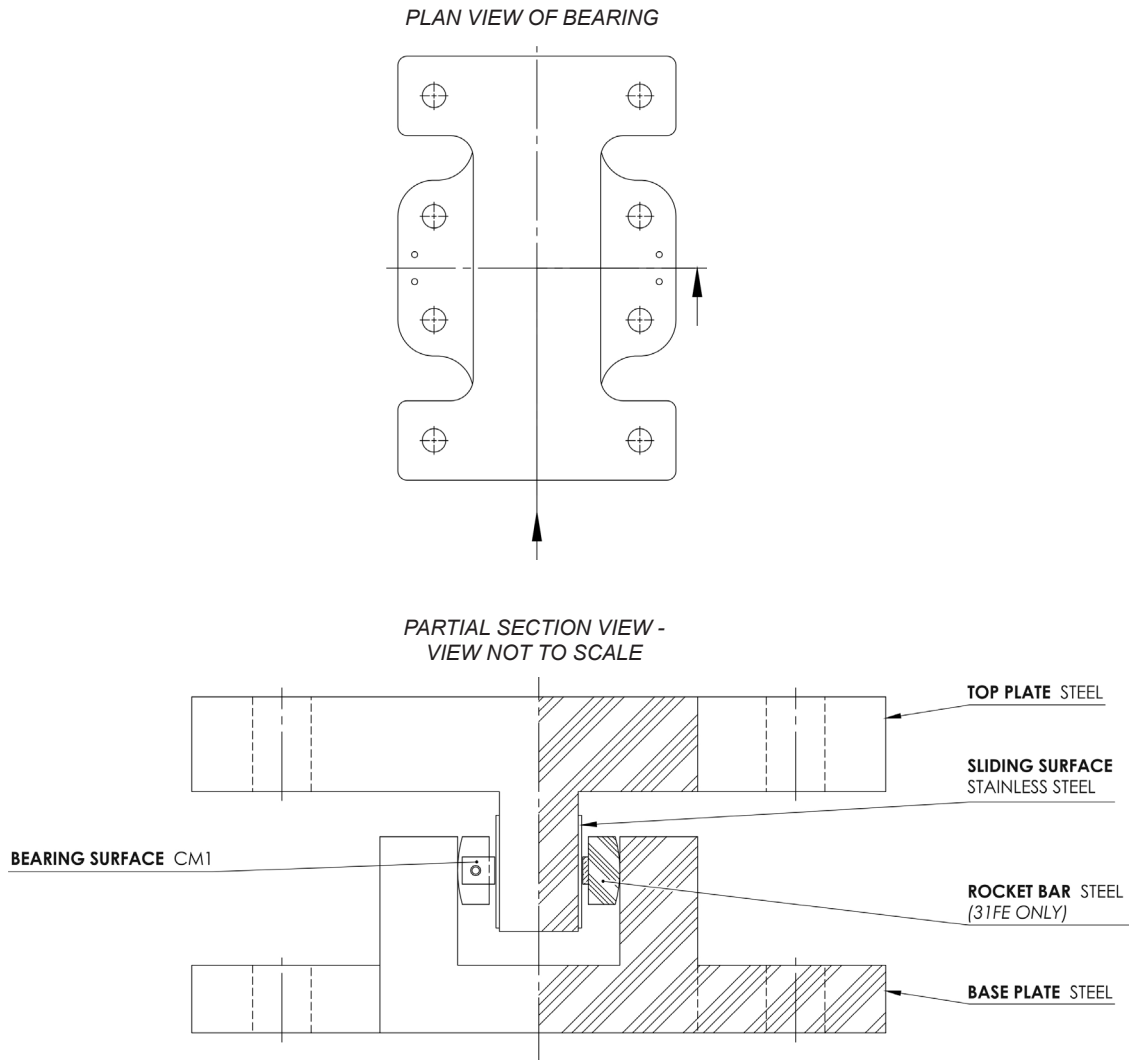

Attachment

All three types, 10FE, 21FE and 31FE, have the facility for bolted attachment of the top and base to sockets, or an independent tapered/adaptor plate.

Support and Installation

Important - See pages 8 - 10 for Installation and Maintenance.

The bearings are fitted with transport brackets which maintain a clearance for vertical movement. These must be removed after installation.

Concrete Stress

Where suitable reinforcement has been provided the allowable concrete stress is dependent on the relative dimensions of the bearing/structure interface, the total support area and the characteristic strength of the concrete. The stress on the structure should therefore be checked to ensure that it is acceptable.

With these bearings it is important to ensure that the sockets are embedded in structural concrete not less than the depth indicated on page 7. A material of adequate strength must be used in conjunction with suitable reinforcement to resist bursting and tensile forces.

Design Loads

Bearings are designed to ultimate limit state criteria in accordance with EN1337-1, EN1337-2 and EN1337-8.

Rotation

The 10FE and 21FE bearing is designed to accommodate rotations in both the transverse and longitudinal direction of 0.01 radians.

The 31FE bearing is designed to allow an enhanced rotation capacity of 0.04 radians transversely and 0.01 radians longitudinally.

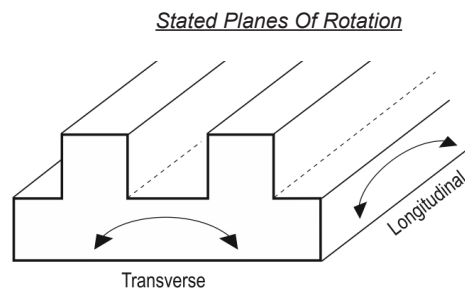

Translations

The dimensions for the 21FE and 31FE bearings allow for a longitudinal translation of ± 50mm. Additional translations can be accommodated. Please contact our sales team for further information.

Designation of Part No.

The part number of a bearing is simply built up as below –
eg.

	Type	Maximum Working Load (kN)	Movement Longitudinal (mm)	Fixings Top	Fixings Base
a	10FE	224	+ - 0	S	S
b	21FE	217	+ - 50	N	S
c	31FE	217	+ - 50	B	S

The basic part number is shown in the tables on pages 4 and 5. Select the type of attachment required and the smallest bearing in that range which can accommodate the specified operating conditions.

- e.g. For **a** above the full part number would be **10FE25/SS**
- b** above the full part number would be **21FE25/100/NS**
- c** above the full part number would be **31FE25/100/BS**

'c' above denotes a guide bearing with bolted attachment to the top plate and bolts and sockets to the base plate. Maximum load capacity is 224kN SLS/320kN ULS for a 10FE and 217kN SLS/310kN ULS for a 21FE/31FE bearing and total movement capacity is 100mm.

10FE - Restraint

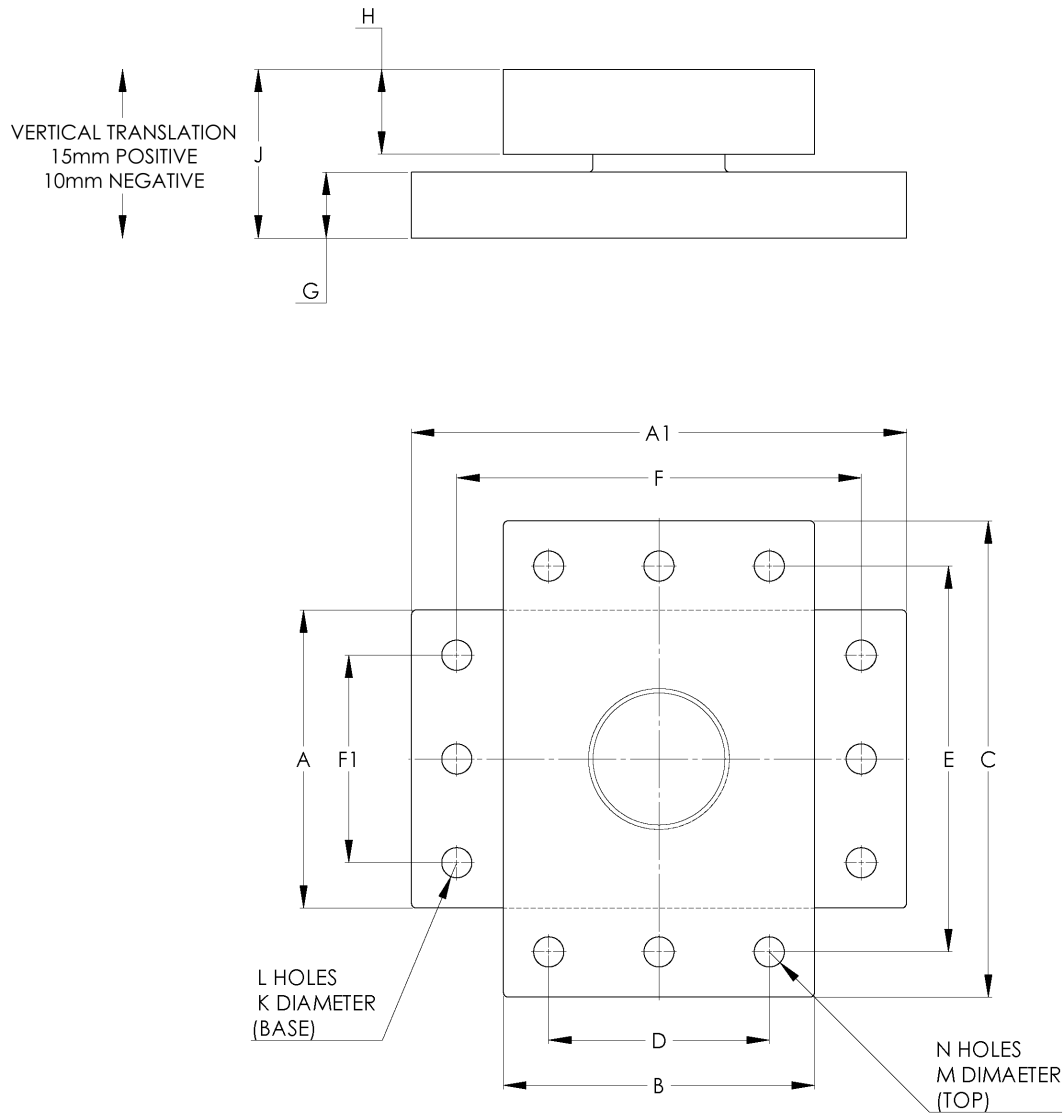

Bearing Part no	Bearing Dimensions (mm)															SLS Load (kN)	ULS Load (kN)	Approx Weight *(Kg)
	A	A1	B	C	D	E	F	F1	G	H	J	K	L	M	N			
10FE15	132	270	140	260	86	196	206	78	35	50	99	18	4	18	4	119	170	24
10FE25	173	335	175	330	97	252	257	95	50	60	128	26	4	26	4	224	320	49
10FE35	220	410	216	390	120	294	314	124	60	75	154	32	4	32	4	392	560	91
10FE75	316	525	330	505	234	409	429	220	70	90	179	32	6	32	6	665	950	205
10FE90	354	595	375	590	261	476	481	240	75	95	188	38	6	38	6	896	1280	283
10FE110	444	700	444	690	310	556	586	310	90	110	220	44	6	44	6	1260	1800	471

* Weight excludes fixings

21FE - Guided

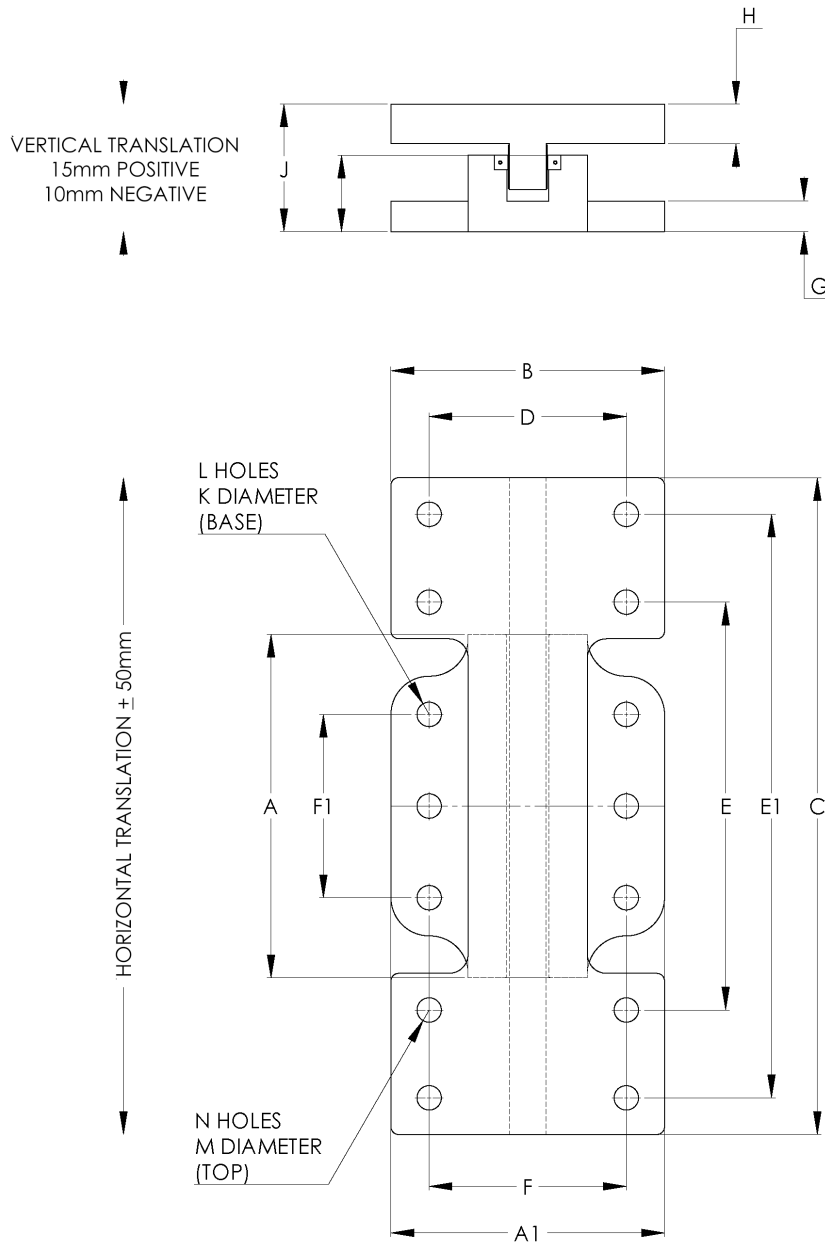

Bearing Part no	Bearing Dimensions (mm)															SLS Load (kN)	ULS Load (kN)	Approx Weight *(Kg)	
	A	A1	B	C	D	E	E1	F	F1	G	H	J	K	L	M				N
21FE15	240	216	216	410	150	335	0	150	105	25	35	125	22	4	22	4	144	205	35
21FE25	290	270	270	470	190	382	0	190	120	30	45	148	26	4	26	4	217	310	58
21FE35	340	310	310	525	214	429	0	214	140	37	50	163	32	4	32	4	322	460	85
21FE75	450	358	358	860	258	534	764	258	240	40	52	167	32	6	32	8	651	930	174
21FE90	530	390	390	970	275	610	855	275	280	52	57	190	38	6	38	8	980	1400	246
21FE110	620	465	465	1150	335	685	1015	335	330	60	68	211	44	6	44	8	1400	2000	402

* Weight excludes fixings

For all enquiries or advice please contact us at enquiry@ekspan.co.uk or call +44 (0) 114 2611126

31FE - Enhanced Guided

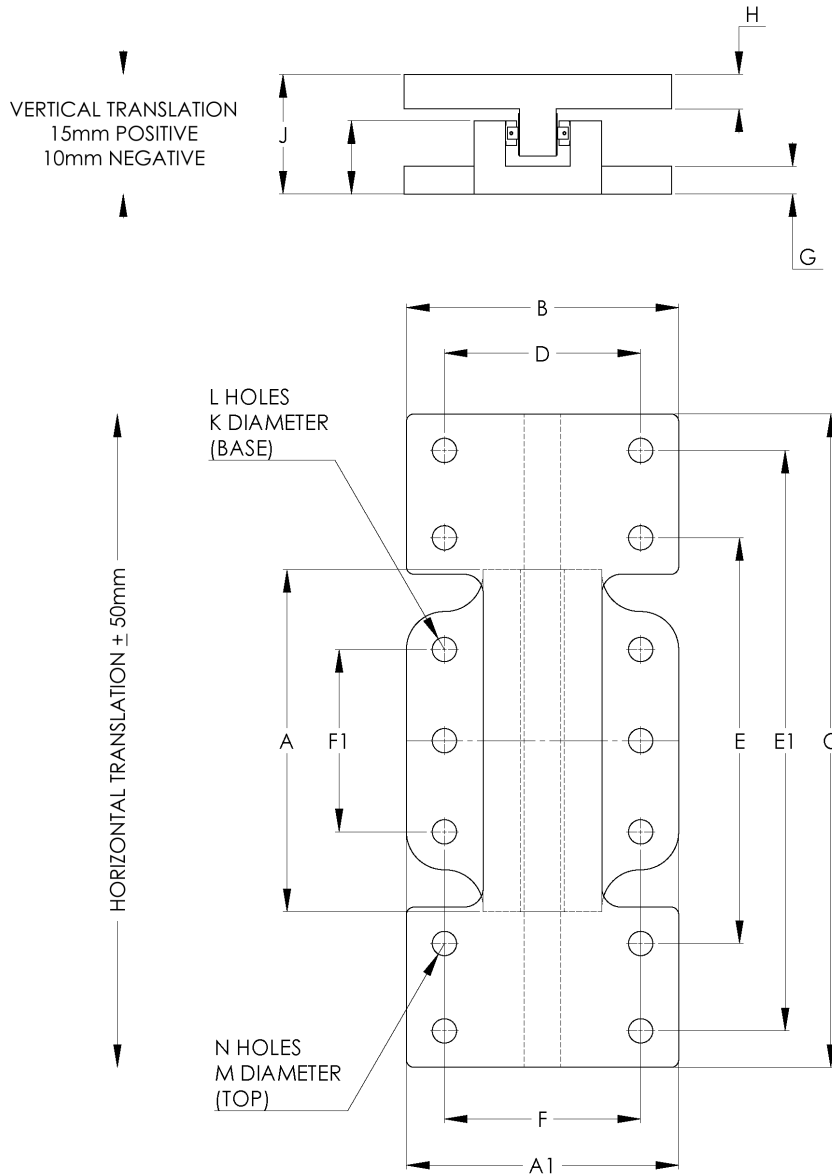

Bearing Part no	Bearing Dimensions (mm)															SLS Load (kN)	ULS Load (kN)	Approx Weight *(Kg)	
	A	A1	B	C	D	E	E1	F	F1	G	H	J	K	L	M				N
31FE15	250	234	234	430	168	335	0	168	110	25	34	130	22	4	22	4	144	205	40
31FE25	290	308	308	470	228	382	0	228	115	30	42	149	26	4	26	4	217	310	68
31FE35	350	352	352	530	256	434	0	256	140	35	49	161	32	4	32	4	322	460	101
31FE75	450	387	387	860	287	534	764	287	240	40	50	173	32	6	32	8	651	930	193
31FE90	550	420	420	980	305	600	835	305	280	45	56	188	38	6	38	8	980	1400	272
31FE110	620	512	512	1115	382	655	985	382	330	55	70	215	44	6	44	8	1400	2000	455

* Weight excludes fixings

Standard FE Series Fixings

The fixings detailed below are designed to suit the requirements of FE Series bearings

By adding a two letter suffix to the bearing part number the type of fixing may be designated -

First letter - Top plate fixing
 Second letter - Base plate fixing

- N** - No fixings
- B** - Bolts and washers only
- S** - Bolts, washers & sockets

e.g. /BS signifies -
 B (top plate fixing) Bolts & washers
 S (base plate fixing) Bolts, washers & sockets

N.B. If standard FE series fixings are not used, care should be taken to ensure that bolts can be fitted without dismantling the bearing.

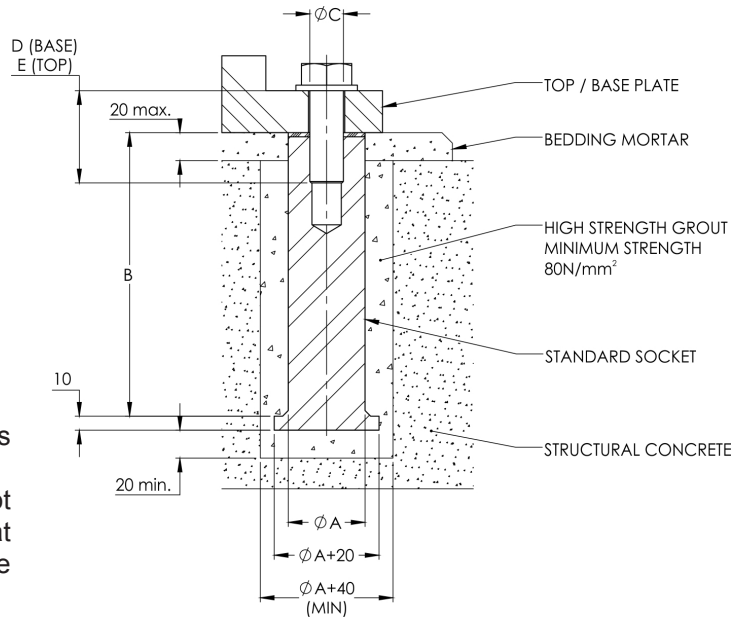

Bolts are hexagon head to either BS EN ISO 4014 or BS EN ISO 4017 grade 10.9.
 Sockets are steel to EN 10025 grade S275.

Bolts and Sockets - 10FE

Bearing Size	Base				Top			
	Socket (mm)		Bolt (mm)		Socket (mm)		Bolt (mm)	
	A	B	C	D	A	B	C	E
10FE15	40	140	16	65	40	140	16	80
10FE25	55	200	24	90	55	200	24	100
10FE35	70	240	30	110	70	240	30	120
10FE75	70	240	30	120	70	240	30	140
10FE90	80	300	36	140	80	300	36	160
10FE110	105	360	42	160	105	360	42	180

Bolts and Sockets - 21FE and 31FE

Bearing Size	Base				Top			
	Socket (mm)		Bolt (mm)		Socket (mm)		Bolt (mm)	
	A	B	C	D	A	B	C	E
21/31FE15	50	170	20	60	50	170	20	70
21/31FE25	55	200	24	70	55	200	24	90
21/31FE35	70	240	30	90	70	240	30	100
21/31FE75	70	240	30	90	70	240	30	100
21/31FE90	80	300	36	110	80	300	36	120
21/31FE110	105	360	42	130	105	360	42	140

Handling, Storage, Installation and Maintenance

Installation

CONSIDER THE EFFECTS IF BEARINGS ARE NOT CORRECTLY INSTALLED

Our structural bearings are manufactured to close tolerances by skilled technicians working in clean conditions. To obtain the requisite performance from bearings it is imperative that they are properly handled at the work site and installed with the same care as when they were assembled in the factory. The following notes will assist those responsible for specifying and supervising the installation of structural bearings. Please note that Ekspan are able to provide installation and supervision.

Bearings must be installed with precision to meet the bridge and bearing design criteria.

Storage

Our structural bearings are protected from contamination under normal working conditions by an efficient sealing system. Care should be taken in storage to prevent contamination and damage to the working surfaces.

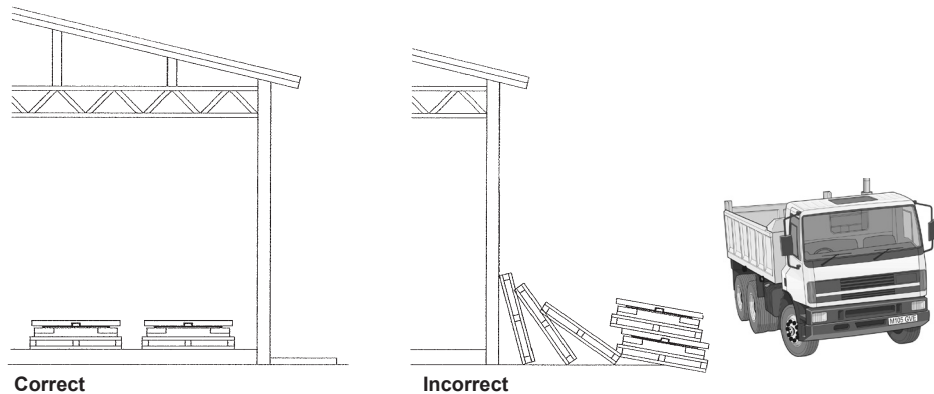

Handling

Robust transportation devices are fitted to all bearings to ensure that the components are maintained in their correct relative positions before and during installation. The devices are normally finished in red paint. Unless special devices have been specified, they should not be used for slinging or suspending the bearings beneath beams.

Due to unpredictable conditions, which may occur during transportation or handling on site, the alignment and presetting (if applicable) of the assembled bearing should be checked against the drawing. Do not endeavour to rectify any discrepancies on site. The bearing should either be returned to Ekspan or, where practical, an Ekspan engineer should be called in to inspect and reassemble. Bearings too heavy to be lifted by hand should be properly slung using lifting equipment.

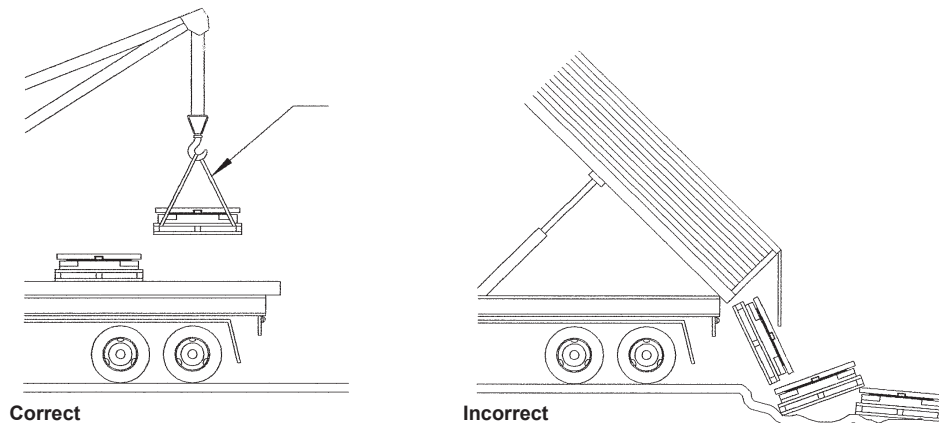

Handling, Storage, Installation and Maintenance

Presetting

If bearings are required to be preset eg where once only large movements may occur during stressing operations, this should be specified as a requirement and should only be carried out in our works prior to despatch. Do not attempt this operation on site.

Bedding

Bearings must be supported on a flat rigid bed. Steel spreader plates must be machined flat and smooth to mate exactly with the bearings' upper and lower faces. Bearings may also be bedded on epoxy or cement mortar or by dry packing. Whichever system is preferred for the particular structure it is of extreme importance that the final bedding is free from high or hard spots, shrinkage, voids, etc.

Unless there is a specific design requirement, the planar surfaces must be installed in a horizontal plane. The correct installation of bearings is vital for the bearing performance. Costly repairs become necessary all too often due to inadequate specification or poor site supervision. The bearings should not be loaded until the bedding mortar has cured.

Fixing bearings to concrete using permanent anchor plates

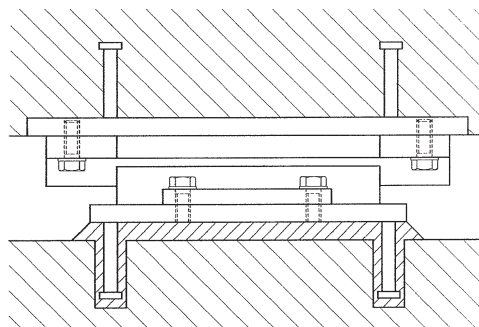

Cast-in-situ structures

Care must be taken to ensure that the bearings are not damaged by the formwork or contaminated by concrete seepage. The interface between the top plate and the formwork should be protected and sealed. Owing to the loading effects of a wet concrete mass, the top plates should be propped to prevent rotation and plate distortion.

Fixing cast-in-situ structures ensure that the bearing working surfaces are protected and supported to prevent distortion and rotation

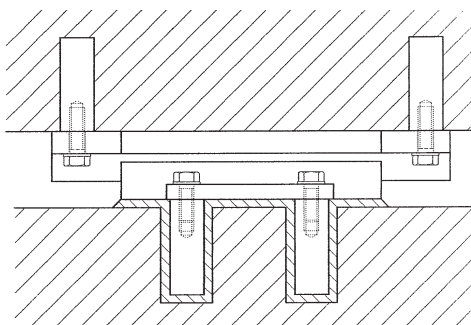

Bearing Removability

Where possible, bearings should be fixed in such a manner as to facilitate removal. Our bearings have generally been designed with this in mind. However, when selecting the bearing type preferred, the removability feature should be highlighted in your enquiry.

Handling, Storage, Installation and Maintenance

Removal of Transport Brackets

These brackets, normally painted red should only be removed once the bearing is properly installed and ready for operation.

Bearing Installation Check List

- DO -**
1. Handle carefully and where necessary with adequate craneage.
 2. Store in a clean dry place.
 3. Ensure that the bearings are installed in the correct location and orientation.
 4. Ensure that the bearings are installed on a flat rigid bed before the design loads are applied.
 5. Ensure that the fixings are uniformly tightened.
 6. Complete any site coatings and make good paint damaged during handling and installation.
 7. Protect working surfaces during the placing of in-situ concrete.
 8. Keep the bearings and surrounding areas clean.
 9. Remove any temporary transit clamps etc. before the bearings are required to operate.
 10. Take special care to support top plates when casting in-situ concrete.
- DO NOT -**
1. Dismantle the bearing on site.
 2. Leave bearings uncovered.
 3. Attempt to modify without our approval.
 4. Install without qualified supervision.

Site Coating

Care should be taken to ensure that working surfaces are not damaged in any site coating operation. After installation damaged coatings must be repaired irrespective of any call for site coatings.

Exposed fixing bolts should be protected after final tightening. Any tapped holes exposed after removal of transportation brackets etc. (coloured red) should be sealed with self-vulcanizing silicone sealant.

Routine Maintenance of Bearings

1. Immediately following installation bearings shall be inspected to ensure that all aspects of 'Installation of bearings' have been adhered to and bearings shall subsequently be re-inspected not less frequently than every two years after their installation.
2. Paint and /or other specified protective coatings must be maintained in good and efficient condition and free from scratches or chips. Any areas of the protective coating showing damage or distress must be rectified.
3. Areas surrounding the bearings must be kept clean and dry and free from the adverse effects of external influences such as airborne debris or water/salt (for example emanating from leaking joints).
4. The wearing surfaces of the bearing must be checked to ensure that they are continuing to operate efficiently.
5. Fixing bolts must be checked for tightness.
6. Any bedding material showing signs of distress or ineffectiveness must be replaced and the reason for its failure investigated and corrected.
7. Routine inspections shall include a check that translational and rotational capacities of the bearing have not been exceeded and show no sign of being likely to exceed the requirements specified at the design stage.

NOTES

FE - SERIES EN1337-8

Quality Structural Bearings

BRIDGE & INDUSTRIAL BEARINGS



B Series Sliding Bearings
with elastomer base

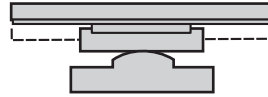

D Series Line Rocker Bearings



EA Series Sliding Bearings



E Series Anticlastic Bearings



Elastomeric Bearings

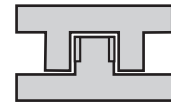

F & FE Series
Pin and Guide Bearings



G & GE Series
Spherical Bearings



K & KE Series Pot Bearings

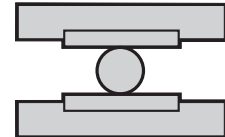

J Series Roller Bearings

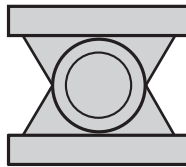

Link Bearings

EXPANSION & SEAL TYPE JOINTS



Multi Element Expansion Joints



Roller Shutter Expansion Joints



Finger Type Expansion Joints



TF Expansion Joints



T-Mat Expansion Joints



TF B-75 and TF B-7
Expansion Joints



Single Element Expansion Joints



EC Seal Expansion Joints



ES Seal Expansion Joints



EW Seal Expansion Joints

A world wide service offering effective solutions in:-
Inspection • Design • Manufacture • Supply
Installation • Commissioning • Planned Maintenance

Ekspan warrants that products described in this brochure are free from defects in workmanship and material but unless expressly agreed in writing Ekspan gives no warranty that these products are suitable for any particular purpose or for use under any specific conditions notwithstanding that such purpose would appear to be covered by this publication. Ekspan accepts no liability for any loss, damage or expense whatsoever arising directly or indirectly from the use of their products or recommendations. All business undertaken by Ekspan is subject to their standard conditions of sale, copies of which are available upon request. Ekspan products are subject to continual development and Ekspan reserves the right to make changes in the specification and design of their products without prior notice.

Issue 01 - September 2017

E&OE



Certificate No.: LKQ 4008849

Ekspan Limited, Compass Works, 410 Brightside Lane, Sheffield S9 2SP, United Kingdom

Tel: +44 (0)114 2611126 • Fax: +44 (0)114 2611165

E-mail: enquiry@ekspan.co.uk • Website: www.ekspan.com



Certificate No.: LKQ 4008850